

VicForests Instructions

September 2009

Code of Procedure for Log Buyers

Log Specifications

Version 2.2



Copyright © VicForests Pty Ltd

All rights reserved. No part of this document may be reproduced, stored in a retrieval system, or transmitted in any form or by any means electronic, mechanical, photocopying, recording or otherwise, without prior written permission of VicForests.

Document Information

File Name:	J:\VICFORESTS\SALES\1. CUSTOMER\5. PRODUCT GRADING\SPECIFICATIONS\CODE OF PROCEDURE LOG BUYER LOG SPECIFICATIONS 28AUG2008_V2.DOC
Description:	Code of Procedure for Log Buyers – Log specs
Author:	Anne Geary
Creation Date:	25 July 2007
Current Revision Author(s):	Anne Geary
Last Updated:	10 September 2009
Version:	2.2
Copy Number:	1

Revision History

Version	Revision Date	Author(s)	Revision Notes
1.0	25 July 2007	A Geary	Update to Tables
2.1	21 August 2008	A Geary	MSL Specification, and UP update
2.2	8 September 2009		Salvage Specs, poles

Reviewers

Reviewer	Position
Bruce McTavish	Manager Product Delivery, CH
Charles Stansfield	Manager Product Delivery, EG
Margaret McCarthy	Analyst, Sales
Michael Theobald	Manager Operations, EG
Stu O'Brien	Senior Forester, Harvesting, CH
Les Coles	Customer Service Manager, EG
Marilyn Rush	Manager Operational Audit & Quality Systems

Approval

Approver	Position	Date
Signature:		

TABLE OF CONTENTS

1.	PREAMBLE	3
2.	PRODUCT GRADE CODES	3
3.	SAWLOG SPECIFICATIONS	4
4.	SALVAGE SAWLOG GRADING SPECIFICATION	9
5	PULPLOG SPECIFICATIONS.....	14
6	OTHER TIMBER SPECIFICATIONS	17
	Attachment 1: Sawlog Species Codes.....	19
	Attachment 2: Sawlog Grading Procedure and Interpretations.....	21
	Attachment 3: Off Specification Timber Procedure.....	26
	Attachment 3 (a): Off Specification Notification	27
	Attachment 4: Procedure: Variation to Pulplog Grade	28
	Attachment 5: Firewood Species and Grade Codes.....	30

All printed copies of this procedures are uncontrolled. The latest version can be found at www.vicforests.com.au

Version: 2.1

Guardian: Manager, Sales

Last Updated: 10/09/09

Authorised: Director – Sales and Planning

1. PREAMBLE

This document details the log specifications for Timber sold by VicForests.

This Code should be read in conjunction with the following Codes:

- Code of Procedure for Sawlog Buyers
- Code of Procedure for Pulplog Buyers
- Code of Procedure for Other Timber Buyers.

2. PRODUCT GRADE CODES

VicForests uses a standard set of product grade codes to identify the specified Timber Types for Log Buyers. These are set out in Table 1 below.

Table 1: Log Grade Product Codes

Product Group	Grade Code	Grade Name
Sawlog	B	B grade sawlogs
	C	C grade sawlogs
	D	D grade sawlogs
	U	Ungraded sawlog:-D grade or better
	E	E1 grade sawlogs
E2 grade sawlogs		
Pulplog	H	High Quality (pulp)
	M	Medium Quality (pulp)
	L	Low Quality (pulp)
Other Timber	F	Dry (firewood)
	G	Green (firewood)
	P	Poles/Piles/Posts

All printed copies of this procedures are uncontrolled. The latest version can be found at www.vicforests.com.au

Version: 2.1

Guardian: Manager, Sales

Last Updated: 10/09/09

Authorised: Director – Sales and Planning

3. SAWLOG SPECIFICATIONS

3.1 The Hardwood Sawlog Grading Card

The Hardwood Sawlog Log Grading Card shown in Diagram 1 is the standard used to grade all sawlogs produced by VicForests in all supply zones.

Diagram 1

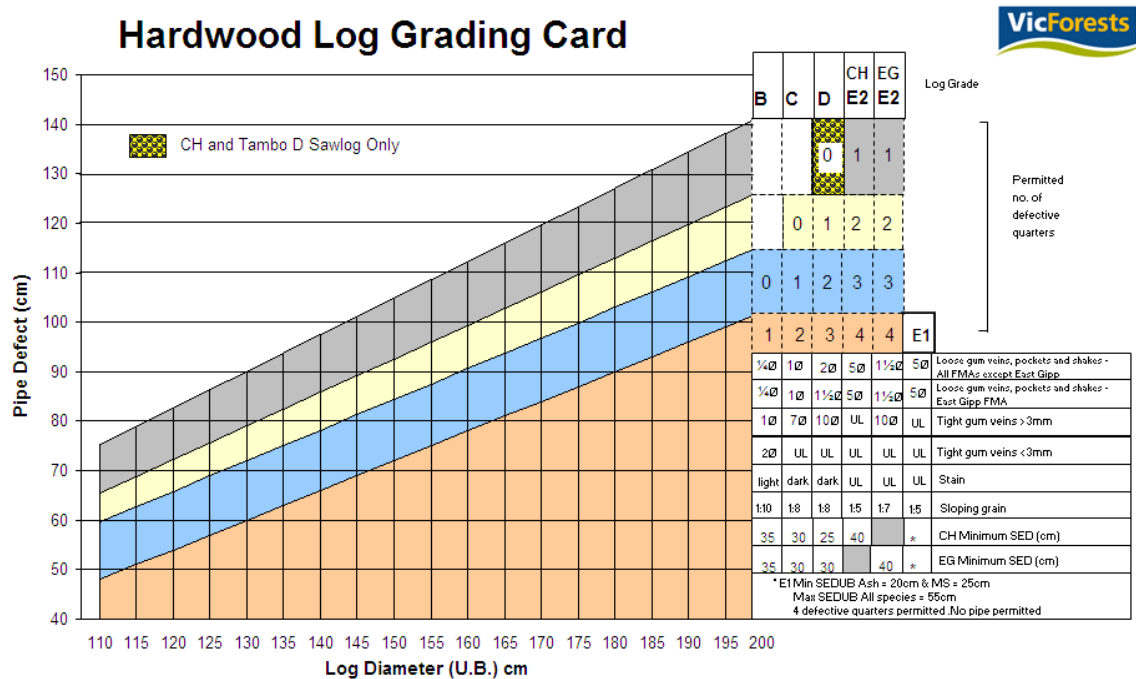
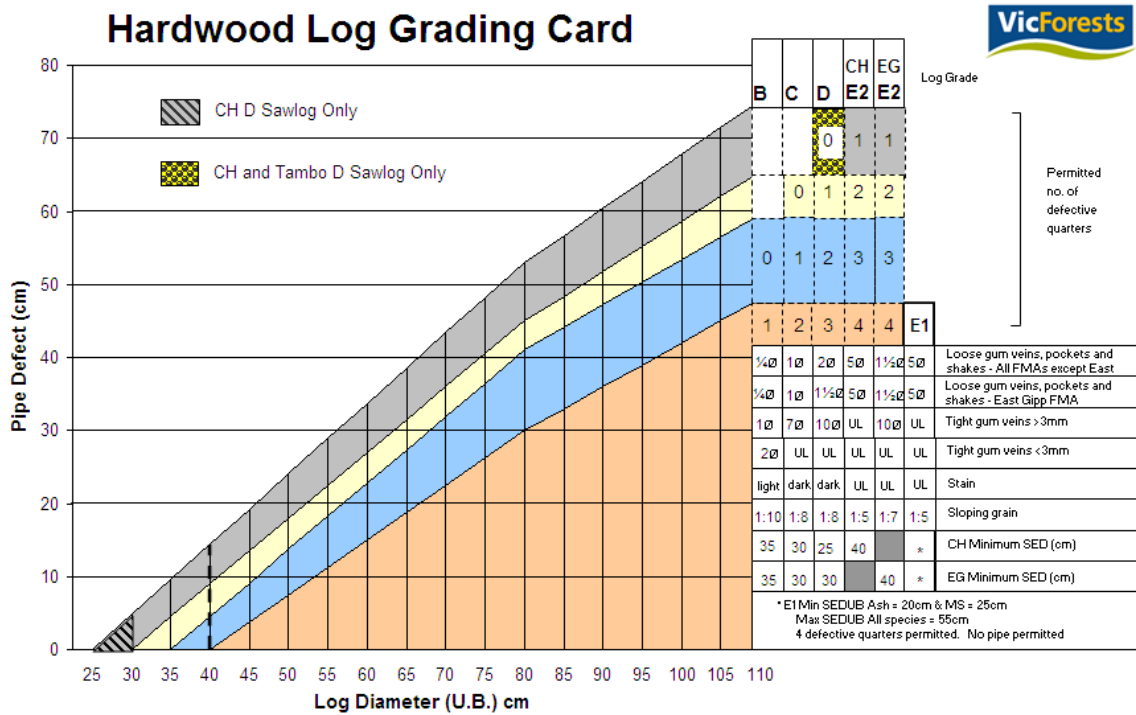

All printed copies of this procedures are uncontrolled. The latest version can be found at www.vicforests.com.au

Version: 2.1

Guardian: Manager, Sales

Last Updated: 10/09/09

Authorised: Director – Sales and Planning

3.2 Sawlog Timber Specifications

The sawlog timber specifications for VicForests timber grades are set out in the tables below.

**Table 2: B, C and D Grade Sawlog Timber Specifications:
All Areas other than East Gippsland FMA**

Parameter		Specification		
Timber		B Grade	C Grade	D Grade
Minimum small end diameter under bark (cm)		35	30	25
Log diameter under bark (cm)				
25-29	Permitted number of defective quarters with no pipe defect	n/a	n/a	0
30-34		n/a	0	1
35-39		0	1	2
>=40		1	2	3
Minimum graded length (m)		2.7	2.7	2.7
Loose gum veins or pockets or shakes		up to ¼ diameter under bark	up to the diameter under bark	up to twice the diameter under bark
Tight gum veins greater than 3mm		up to 1 diameter under bark	up to 7 diameter under bark	up to 10 diameter under bark
Tight gum veins less than 3 mm		up to twice the diameter under bark	Unlimited	Unlimited
Stain*		Light stain* only	tolerated	tolerated
Sloping grain		maximum of 1 in 10	maximum of 1 in 8	maximum of 1 in 8

1. No timber may have a sweep or crook which is greater than one-fifth of the diameter under bark of that timber at the apex of the sweep or crook, measured from a straight edge inside the sweep or crook of at least 2.4 metres.
2. No timber may have a pipe defect which exceeds the permissible size for the relevant grade of timber set out in the Hardwood Timber Grading Card published by VicForests. For the purpose of this paragraph, a "defect" is a feature affecting other than the surface or sapwood of a timber which prevents sawn timber of any merchantable grade being recovered from some or all of a timber.

All printed copies of this procedures are uncontrolled. The latest version can be found at www.vicforests.com.au

Version: 2.1

Guardian: Manager, Sales

Last Updated: 10/09/09

Authorised: Director – Sales and Planning

Table 3: B, C and D Grade Sawlog Timber Specifications - East Gippsland FMA

Parameter		Specification		
Timber		B Grade	C Grade	D Grade
Minimum small end diameter under bark (cm)		35	30	30
Log diameter under bark (cm)				
N/A	Permitted number of defective quarters with no pipe defect	n/a	n/a	0
30-34		n/a	0	1
35-39		0	1	2
>=40		1	2	3
Minimum graded length (m)		2.7	2.7	2.7
Loose gum veins or pockets or shakes		up to ¼ diameter under bark	up to the diameter under bark	up to 1.5 times the diameter under bark
Tight gum veins greater than 3mm		up to 1 diameter under bark	up to 7 diameter under bark	up to 10 diameter under bark
Tight gum veins less than 3 mm		up to twice the diameter under bark	Unlimited	Unlimited
Stain*		Light stain* only	tolerated	tolerated
Sloping grain		maximum of 1 in 10	maximum of 1 in 8	maximum of 1 in 8

* Stain means the colour of solid wood, unaffected by defects such as rot.

* Light stain means a stain from which appearance grade sawn timber can be recovered.

1. No timber may have a sweep or crook which is greater than one-fifth of the diameter under bark of that timber at the apex of the sweep or crook, measured from a straight edge inside the sweep or crook of at least 2.4 metres.
2. No timber may have a pipe defect which exceeds the permissible size for the relevant grade of timber set out in the Hardwood Timber Grading Card published by VicForests. For the purpose of this paragraph, a "defect" is a feature affecting other than the surface or sapwood of a timber which prevents sawn timber of any merchantable grade being recovered from some or all of a timber.

All printed copies of this procedures are uncontrolled. The latest version can be found at www.vicforests.com.au

Version: 2.1

Guardian: Manager, Sales

Last Updated: 10/09/09

Authorised: Director – Sales and Planning

Table 4: E Grade Sawlog Timber Specifications - All Areas

Parameter	Specification		
	E1 Grade	E2 Grade	E2 Grade
		All FMA's excluding East Gippsland FMA	East Gippsland FMA
Minimum small end diameter under bark (cm)	20 for Ash spp 25 for Mixed spp	40 for all species	40 for all species
Maximum small end diameter under bark (cm)	55 for all spp	Unlimited	Unlimited
Permitted number of defective quarters	4	Refer to the Log Grading Card	Refer to the Log Grading Card
Minimum clearwood length within one quarter over a 2.7 m length (m)	1.2	1.2	Unlimited
Minimum graded length (m)	2.7	2.7	2.7
Allowable pipe	None	Not to exceed the maximum allowable pipe for a D grade log	As per the East Gippsland FMA Hardwood Sawlog Grading Card
Loose gum veins or pockets or shakes	Up to 5 times the log diameter under bark	Up to 5 times the log diameter under bark	Up to 1.5 times the log diameter under bark
Tight gum veins greater than 3mm	Unlimited	Unlimited	Up to 10 times the log diameter under bark
Tight gum veins less than 3 mm	Unlimited	Unlimited	Unlimited
Stain *	Unlimited	Unlimited	Unlimited
Sloping grain	Maximum of 1 in 5	Maximum of 1 in 5	Maximum of 1 in 7

* Stain means the colour of solid wood, unaffected by defects such as rot.

1. No timber may have a sweep or crook which is greater than one-fifth of the diameter under bark of that timber at the apex of the sweep or crook, measured from a straight edge inside the sweep or crook of at least 2.4 metres.

All printed copies of this procedures are uncontrolled. The latest version can be found at www.vicforests.com.au

Version: 2.1

Guardian: Manager, Sales

Last Updated: 10/09/09

Authorised: Director – Sales and Planning

3.3 Ungraded Sawlog

Logs sold by weight by the log load are usually sold as ungraded sawlogs.

The specifications for Ungraded sawlogs are as per the specifications for D grade and better sawlogs, however individual grades are not identified in each log. Where more than one species is present the species is to be identified on each log. Ungraded sawlogs may be supplied by weight using the stipulated weight to volume conversion factor for Ash species and MS species.

All printed copies of this procedures are uncontrolled. The latest version can be found at www.vicforests.com.au

Version: 2.1

Guardian: Manager, Sales

Last Updated: 10/09/09

Authorised: Director – Sales and Planning

4. SALVAGE SAWLOG GRADING SPECIFICATION

Salvage Sawlog Grading Specifications apply to salvage logs of ash species from designated fire events which include the 2006/07 and the February 2009 fires.

These specifications may be reviewed periodically.

In this Section, reference to “Green” means the standard specifications applicable to green, non-fire affected logs.

4.1 Cracking

4.1.1 When does a salvage log become a “cracked” log?

Dry, longitudinal cracks occur where trees have been killed as a result of fire and the outside of the tree has dried due to exposure to wind and sun.

Logs are to be classified as “cracked” where greater than 50% of the log length and 25% of the circumference of a log has been affected.

Logs with less than this level of checking will be assessed as green logs

The maximum level of cracking permissible is dependent on the depth of dry cracks and the diameter of the log. The minimum and maximum levels of cracking is as follows:-

Assessed Cracking Depth	Cracking Extent	Actual Log Diameter - < 55cm	Actual Log Diameter - > 55cm
<2cm	Minimum	25% of circumference 50% of log length	25% of circumference 50% of log length
	Maximum	50% of circumference Full log length	100% of circumference Full log length
2-5cm	Minimum	N/a	25% of circumference 50% of log length
	Maximum	N/a	50% of circumference Full log length

4.1.2 Measuring cracks and classifying “cracked logs”

Where cracking exceeds the minimum threshold outlined in 4.1.1, the depth of the cracks are to be measured as follows:

- Assess the worst affected end of the log
- Identify the deepest cracks
- Measure the shortest of the 4 deepest cracks at the end of the log and mark with crayon.

For the purpose of classifying “cracked” logs the following four classes apply:

- 0-2cm
- 2-5cm

All printed copies of this procedures are uncontrolled. The latest version can be found at www.vicforests.com.au

Version: 2.1

Guardian: Manager, Sales

Last Updated: 10/09/09

Authorised: Director – Sales and Planning

- 5-10cm
- 10cm+

B, C and D grade sawlogs with 0-2cm cracking depth are marked with an X as follows:

- Alpine Ash - XAB, XAC or XAD
- Mountain Ash - XMB, XMC or XMD
- Shining Gum - XSB, XSC or XSD

B, C and D grade sawlogs with 2-5cm cracking depth are marked with a Z as follows:

- Alpine Ash - ZAB, ZAC or ZAD
- Mountain Ash - ZMB, ZMC or ZMD
- Shining Gum - ZSB, ZSC or ZSD

Logs with cracking depth of greater than 5cm are not marked.

4.1.3 Grading and Pricing of “cracked logs”

The normal “green” grading and pricing of “cracked logs” is varied as per the Table in 4.1.4 depending on the assessment of the depth of cracking and the resulting class of cracking.

Log Diameter is to be recorded and marked as actual diameter and the invoicing system will reduce the actual recorded diameter by the adjustment shown in the Table in 4.1.4 when calculating delivered prices

- (i) “Cracked logs” where cracks are 0 to 2 cm deep:
The delivery charges for logs with cracks of 0 to 2 cm deep will be decreased by reducing the invoiced diameter of all B, C and D grade logs by 6cm.
- (ii) “Cracked logs” where cracks are 2 to 5 cm deep:
The delivery charges for logs of >55cm with cracks of 2 to 5cm deep will be decreased by reducing the invoiced diameter of all B, C and D grade logs by 8cm.
There will be no delivery charge decrease for logs 35-54cm SEDUB with 2 to 5 cm cracks. These products will be downgraded prior to delivery.
- (iii) “Cracked logs” where cracks are greater than 5 cm deep:
There will be no delivery charge decrease for logs with greater than 5 cm cracks. These products will be downgraded prior to delivery.

4.1.4 Salvage Grading Decision Tree

Does dry cracking impact greater than 50% of the log length and 25% of the circumference?

No – Grade as normal (Green log).

Yes – Measure the shortest of the 4 deepest cracks at the worst effected end of the log and grade as per table.

Assessed Cracking Depth	25< Diam <35 cm SEDUB	Cracking Extent	35.1< Diam <40.0 cm SEDUB	40.1< Diam <55.0 cm SEDUB	Diam >55.1 cm SEDUB	Delivered Price Diameter Reduction
<2cm	E	>Min;<Max	C	B	B	6cm
		>Max	E	D	n/a	0cm
		>Min;<Max	C	C	C	6cm
		>Max	E	D	n/a	0cm
		>Min;<Max	D	D	D	6cm
		>Max	E	E	n/a	0cm
2-5cm	P	>Min;<Max	E	D	B	8cm
		>Max			D	0cm
		>Min;<Max	E	D	C	8cm
		>Max			D	0cm
		>Min;<Max	E	D	D	8cm
		>Max			E	0cm
5-10cm	P	N/a	E	E	E2 or D >70cm	0cm
>10cm	P	N/a	P	P	P	0cm

Within the limitations of normal log segregation log lengths between 6.2m and 8.6m should be minimised in fire salvage stands.

All printed copies of this procedures are uncontrolled. The latest version can be found at www.vicforests.com.au

Version: 2.1

Guardian: Manager, Sales

Last Updated: 10/09/09

Authorised: Director – Sales and Planning

Grading Decision Flowchart

Assessed Cracking Depth	25< Diam <35 cm SEDUB	Cracking Extent	Normal Grade (Green)	35.1< Diam <40.0 cm SEDUB	40.1< Diam <55.0 cm SEDUB	Diam >55.1 cm SEDUB
<2cm	E	>Min;<Max	B	C	B	B
		>Max		E	D	
		>Min;<Max	C	C	C	C
		>Max		E	D	
		>Min;<Max	D	D	D	D
		>Max		E	E	
2-5cm	P	>Min;<Max	B	E	D	B
		>Max		E	D	D
		>Min;<Max	C	E	D	C
		>Max		E	D	D
		>Min;<Max	D	E	E	D
		>Max		E	E	E
5-10cm	P	N/a	N/a	E	E	E2 or D >70cm
>10cm	P	N/a	N/a	P	P	P

4.2 Salvage Grading Flowchart

The following flowchart summarises the decision points involved in grading salvage logs.

All printed copies of this procedures are uncontrolled. The latest version can be found at www.vicforests.com.au

Version: 2.1

Guardian: Manager, Sales

Last Updated: 10/09/09

Authorised: Director – Sales and Planning

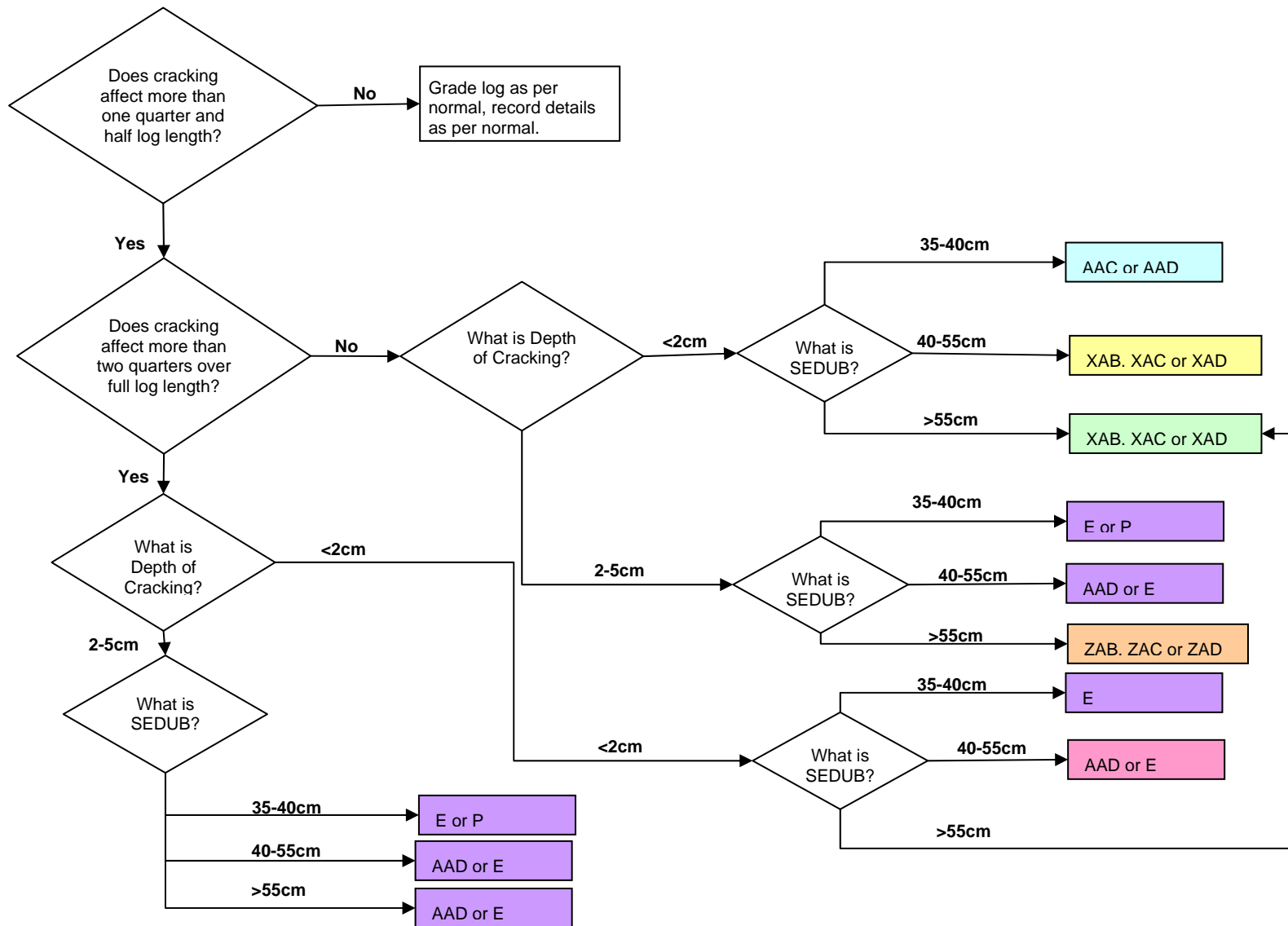

All printed copies of this procedures are uncontrolled. The latest version can be found at www.vicforests.com.au

5 PULPLOG SPECIFICATIONS

5.1 Pulplog Grades

Pulplog grades are based on the timber species and log size class. VicForests pulplog grades by species and size-class, are summarised in Table 5 below.

As pulplog quality may vary by geographic location, site quality and elevation, there is provision for variation of the pulplog grade class by agreement between VicForests and the Buyer. The procedure for variation of pulplog grades is in Attachment 4.

All printed copies of this procedures are uncontrolled. The latest version can be found at www.vicforests.com.au

Version: 2.1

Guardian: Manager, Sales

Last Updated: 10/09/09

Authorised: Director – Sales and Planning

Table 5: Pulplog Species and Size Class Specification

VICFORESTS PULPLOG SPECIFICATIONS			
PULPLOG GRADE BY SPECIES AND SIZE CLASS			
Species Name	Size Class (cm piece size)		
	0 - 40	40 - 60	60+
Mountain Ash (E.regnans)	AS-H	AS-H	AS-H
Alpine Ash (E.delegatensis)	AS-H	AS-H	AS-H
Silver Wattle (A.dealbata)	AS-H	AS-H	AS-H
Black Wattle (A.mearnsii)	AS-H	AS-H	AS-H
Blackwood (A.melanoxylon)	AS-H	AS-H	AS-H
Shining Gum (E.nitens, E.denticulata)	MS-H	MS-H	MS-H
Silvertop (E.sieberi)	MS-H	MS-H	MS-H
Cut tail (E.fastigata)	MS-H	MS-H	MS-H
Manna Gum (E.viminalis)	MS-H	MS-H	MS-H
Blue Gum (E.globulus ssp.)	MS-H	MS-H	MS-H
Mountain Gum (E.dalrympleana)	MS-H	MS-H	MS-H
River Peppermint (E.elata)	MS-H	MS-M	MS-M
Narrow Leaf Peppermint (E.radiata/ E.croajingolensis)	MS-H	MS-M	MS-L (EG FMA)
			MS-M
Messmate (E.obliqua)	MS-H	MS-M	MS-L (EG FMA)
			MS-M
Grey Gum / Monkey Gum (E.cypellocarpa)	MS-H	MS-M	MS-L (EG FMA)
			MS-M
Brown Stringy (E.baxteri)	MS-H	MS-M	MS-L (EG FMA)
			MS-M
Maidens Gum (E.maidenii)	MS-H	MS-M	MS-M
Gully Gum (E.smithii)	MS-H	MS-M	MS-M
Swamp Gum (E.ovata)	MS-H	MS-M	MS-M
Brittle Gum (E. mannifera)	MS-H	MS-M	MS-M
Candle Bark (E.rubida)	MS-H	MS-M	MS-M
Broad Leaf Peppermint (E dives)	MS-H	MS-M	MS-M
Yellow Stringy (E.muellerana)	MS-H	MS-M	MS-L
White Stringy (E.globoidea)	MS-H	MS-M	MS-L
Mahogany (E.botryoides/ E.robusta)	MS-H	MS-M	no
Apple-topped Box (E.angophoroides)	MS-H	MS-M	no
Blue Leaf Stringy (E.agglomerata)	MS-H	MS-M	no
Red Stringy (E.macroryncha)	MS-H	MS-M	no
Ironbark (E.tricarpa)	no	no	no
Woollybutt (E.longifolia)	no	no	no
Greybox, Redbox (E.bosistoana, E.polyanthemos)	no	no	no
Yertchuk (E.consideniana)	no	no	no
Bloodwood (C.gummifera)	no	no	no

All printed copies of this procedures are uncontrolled. The latest version can be found at www.vicforests.com.au

Version: 2.1

Guardian: Manager, Sales

Last Updated: 10/09/09

Authorised: Director – Sales and Planning

5.2 Pulplug: General Specifications

The general specifications and defect tolerances relating to pulplugs are summarised in Tables 6 and 7 below.

Table 6: General Pulplug Specifications

Parameter	Specification
Minimum small end diameter (SED*) under bark	8 cm for both round and split logs
Maximum large end diameter (LED*) under bark	60 cm*
Minimum length	3.0 metres
Maximum length	12.0 metres
Branches	Less than half log diameter and flush trimmed
Charcoal	100 % free
Bark	100 % free
Sweep	Less than diameter over 2.4 metres
Spiral Grain	Less than half diameter over 2.4 meters
Shattered ends and slovens	Removed
Split logs	Acceptable and clean of all rot and mud

* Note that the SED and LED specifications may be varied by agreement for specific buyers.

Table 7: Pulplug Defect Tolerances

Size Class	Permitted Defect
Logs and slabs less than 40 cm diameter	Defect not to exceed 50% of diameter
	Minimum wood depth of 10 cm across the diameter of the log
Logs and Slabs between 40 and 60 cm large end diameter (LED)	Logs must have an average of 10 cm of solid wood between the pipe and outside diameter of the log, for the length of the log
Logs with a pipe of greater than 25 cm	If rot or mud present then must be split with all rot and mud removed.
Logs greater than LED cm	Must be split to render maximum piece size less than 60cm

All printed copies of this procedures are uncontrolled. The latest version can be found at www.vicforests.com.au

Version: 2.1

Guardian: Manager, Sales

Last Updated: 10/09/09

Authorised: Director – Sales and Planning

6 OTHER TIMBER SPECIFICATIONS

6.1 Firewood

Firewood may be specified as green or dry sales.

The specification for firewood timber is shown in the table below:-

Table 8a: Firewood Specifications

Parameter	Specification
Minimum small end diameter under bark	10cm
Maximum large end diameter under bark	Logs over 80cm must be split
Number of defective quarters	Up to 4
Pipe defect	A minimum depth of 10cm of solid wood, measured from the pipe to the outside of the log
Minimum log length	2.7m
Maximum log length	13 m or less
Loose gum veins, pockets or shakes	Unlimited
Tight gum veins greater than 3mm	Unlimited
Tight gum veins less than 3mm	Unlimited
Stain	Unlimited
Sloping grain	1:8
Sweep	No pronounced bends or sharp sweep
Species	As per table in Attachment 5

All printed copies of this procedures are uncontrolled. The latest version can be found at www.vicforests.com.au

Version: 2.1

Guardian: Manager, Sales

Last Updated: 10/09/09

Authorised: Director – Sales and Planning

6.2 Poles, Piles and Posts

For poles, piles and post timber, VicForests negotiates appropriate specifications with interested buyers.

A general specification for poles is shown in the table below:-

Table 8b: Pole Specification

Parameter	Specification
Minimum small end diameter under bark	15 cm
Maximum large end diameter under bark	40 cm
Number of defective quarters	Up to 4
Green limbs	up to 20% of circumference, trimmed flush
Pipe defect	Not permitted
Log length	12 m
Stain and Gum vein	Acceptable
Spiral Grain	Not permitted
Sweep	No pronounced bends or sharp sweep
Species	Eucalypt species as per table in Attachment

All printed copies of this procedures are uncontrolled. The latest version can be found at www.vicforests.com.au

Version: 2.1

Guardian: Manager, Sales

Last Updated: 10/09/09

Authorised: Director – Sales and Planning

Attachment 1: Sawlog Species Codes

The following species codes are used by VicForests to identify timber species.

Species Group	Species Code	Genus	Species	Common Name
AC	AC	Acacia	- not specified -	Acacia species
AC	BW	Acacia	melanoxyton	Blackwood
AC	SW	Acacia	dealbata	Siver Wattle
AM	AM	Eucalyptus	All	Ash and Mixed species
AS	AA	Eucalyptus	delegatensis	Alpine Ash
AS	AS	Eucalyptus	All ash	Mixed ash species
AS	MA	Eucalyptus	regnans	Mountain Ash
AS	SG	Eucalyptus	nitens	Shining Gum
MS	BG	Eucalyptus	- not specified -	Mixed Blue Gum Species
MS	BG	Eucalyptus	bicostata	Eurabbie
MS	BG	Eucalyptus	pseudoglobulus	Victorian Eurabbie
MS	BG	Eucalyptus	maidenii	Maidens Gum
MS	BG	Eucalyptus	globulus	Southern Blue Gum
MS	BS	Eucalyptus	baxteri	Brown Stringybark
MS	BX	Eucalyptus	- not specified -	Box Species
MS	CB	Eucalyptus	rubida	Candlebark
MS	CT	Eucalyptus	fastigata	Cut-tail
MS	CY	Eucalyptus	cypelloarpa	Mountain Grey Gum
MS	DA	Eucalyptus	dalrympleana	Mountain Gum
MS	DE	Eucalyptus	denticulata	Errinundra Shining Gum
MS	GG	Eucalyptus	bosistoana	Gippsland Grey Box
MS	IB	Eucalyptus	tricarpa	Red Ironbark
MS	MM	Eucalyptus	obliqua	Messmate
MS	MS	Eucalyptus	Mixed	Non-ash mixed species
MS	OS	Eucalyptus	- not specified -	Non-ash mixed species
MS	PM	Eucalyptus	- not specified -	Peppermint
MS	PM	Eucalyptus	dives	Broad-leaved Peppermint
MS	PM	Eucalyptus	croajingolensis	
MS	PM	Eucalyptus	radiata/robertsonii	Narrow-leaved Peppermint
MS	PM	Eucalyptus	nitida	Shining Peppermint
MS	PM	Eucalyptus	willisii	
MS	RB	Eucalyptus	polyanthemos	Red Box
MS	RP	Eucalyptus	elata	River Peppermint
MS	RS	Eucalyptus	macrorhyncha	Red Stringybark
MS	SM	Eucalyptus	botryoidies	Southern Mahogany
MS	ST	Eucalyptus	sieberi	Silvertop
MS	VM	Eucalyptus	viminalis	Manna Gum
MS	WS	Eucalyptus	globoidea	White Stringybark
MS	YK	Eucalyptus	consideniana	Yertchuk
MS	YS	Eucalyptus	muelleriana	Yellow Stringybark
SP	BO	Elaeocarpus	holpetalus	Black Olive Berry
SP	CU	Exocarpus	cupressiformis	Cherry Ballart
SP	SA	Atherosperma	moschatum	Sassafrass
SP	SP	Minor	- not specified -	Any Genus not specified
SP	BD	Corymbria	gummifera	Red Bloodwood

All printed copies of this procedures are uncontrolled. The latest version can be found at www.vicforests.com.au

Version: 2.1

Guardian: Manager, Sales

Last Updated: 10/09/09

Authorised: Director – Sales and Planning

Mixed Species Sawlog Species Sub-Groups:

The following species group codes are used where mixed species logs are sold in specified groups of species.

M1	M2	M3	M4	M5*	MS
Messmate Silvertop Cut-tail	Grey gum Stringybarks Peppermints Other Species	Manna Gum Shining Gum (E.denticulata)	Any mixed Species: undefined proportions	Yellow Stringybark Southern Mahogany Ironbark Box Species Blue Gum	Any mixed species: run of bush

Notes

*M5 Species will generally not be included in other sub-groups in EGFMA, and may be specified as individual species in sales contracts and timber lots.

Attachment 2: Sawlog Grading Procedure and Interpretations

1. THE HARDWOOD LOG GRADING PROCEDURE

The following chronological steps are used in grading a log:

1. The log is inspected for any limiting defect or feature that would immediately indicate the grades of the component sawlogs; then
2. Measurement of the diameter under bark at each end of the log, and measurement of the dimensions of any boxed defect that is present; then
3. The applicable Hardwood Log Grading Card and Specification Table is used to determine the permitted number of defective quarters for each grade for the particular diameter under bark and pipe combinations at each end of the log; then
4. The permitted number of defective quarters in the first 2.7 m length of the log is checked and the grade determined for that length; then
5. If the grade continues unchanged immediately after the first 2.7 m length, the point along the log where it is considered that the grade has changed, as determined by the number of defective quarters, short end diameter under bark limitations, and estimated pipe diameter is identified; then
6. Each end of the log is checked to identify the presence of gum and shake affect the grade as determined above.
7. Logs may be cross cut at any grade change points, unless the log is a multigrade log.

2. GRADING INTERPRETATIONS

2.1 Short Logs

The Contractor must ensure that:

- (a) if the short section occurs within a log between two sawlogs:
 - (i) for sections up to 1.2 m it can remain in the log for cartage convenience at the discretion of the VicForests' Customer. In this case the length should be added to the length of the lowest grade sawlog on either side; or
 - (ii) for sections greater than 1.2 m a sawlog of minimum length of the appropriate grade should be prepared but it may remain in the log for cartage convenience at the discretion of the VicForests' Customer.
- (b) if the short section occurs on the end of a log:
 - (i) for sections less than 1.2m the length may be trimmed as waste; or
 - (ii) for sections up to 1.2m it can remain on the log at the discretion of the VicForests' Customer. In this case the length of the section will be added to the length of the lowest grade sawlog in the log; or

All printed copies of this procedures are uncontrolled. The latest version can be found at www.vicforests.com.au

Version: 2.1

Guardian: Manager, Sales

Last Updated: 10/09/09

Authorised: Director – Sales and Planning

- (iii) for sections greater than 1.2m, but less than 2.7m a sawlog of minimum length of the appropriate grade may be prepared at the discretion of the VicForests' Customer; or
- (iv) for sections greater than 1.2m but less than 2.7m where the VicForests' Customer does not wish to take this length it may be trimmed to waste.

2.2 Multigrading

The Contractor must ensure that:

- (a) at landings where logs are being dispatched to Customers accepting a range of log grades, log lengths containing more than one grade are permitted for cartage convenience, provided:
 - (i) grade lengths are clearly identified and recorded in accordance with sub-clause 13.4; and
 - (ii) each section of a multigraded log are a minimum of 2.7m in length; and
 - (iii) the multigraded log must include a 0.1m allowance for cross cutting by the customer.

2.3 Using pipe and defect quarter allowances

The Contractor must ensure that:

- (a) boxing and defect quarters are used where they increase the grade of logs; and
- (b) boxes are measured around the centre of the log (diagram 1) in the following way:
 - (i) measure two diameters at 90 degrees to each other; then
 - (ii) calculate the average of these diameters to determine the pipe defect to be used on the card; then
 - (iii) convert rectangular boxes to a square of approximately equivalent area.
- (c) if the defect falls only in one quarter it should be treated as a defective quarter (diagram 1).

Diagram 1

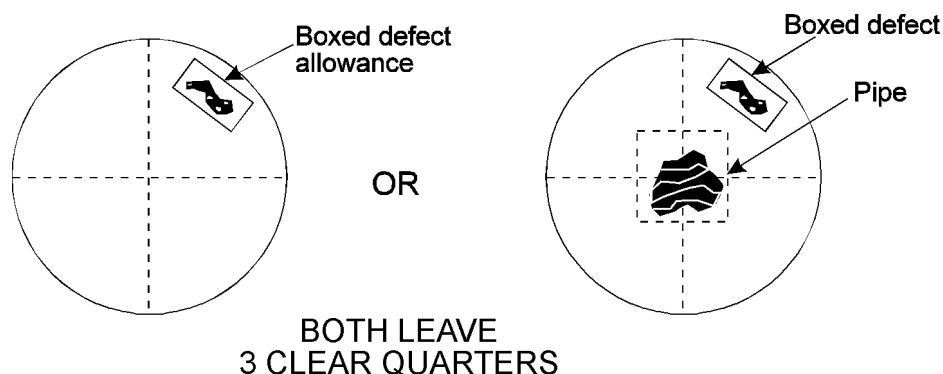

All printed copies of this procedures are uncontrolled. The latest version can be found at www.vicforests.com.au

Version: 2.1

Guardian: Manager, Sales

Last Updated: 10/09/09

Authorised: Director – Sales and Planning

2.4 Gum Veins

- (a) A Contractor must consider the following three types of gum veins when grading logs:
- (i) Tight gum veins less than 3mm in diameter are rings of ribbon or kino running between growth rings that have bridging wood tissue.
 - (ii) Tight gum veins more than 3mm in diameter are rings of ribbon or kino running between growth rings that have bridging wood tissue.
 - (iii) Loose Gum Veins are a ribbon of gum or kino between growth rings that are not joined by any wood tissue. They include gum pockets and shakes.
- (b) A Contractor must measure gum veins as follows:
- (i) Gum veins are to be measured radially and calculated cumulatively;
 - (ii) Loose gum veins are to be measured first and checked against the card to determine the impact on grade;
 - (iii) Tight gum veins greater than 3mm are to be measured next. Add this length to the loose gum veins then check against the card to determine the impact on grade;
 - (iv) Tight gum veins less than 3mm are to be measured last. Add this length to the lengths of both the loose gum veins and tight gum veins greater than 3mm. Check this length against the card to determine the impact on grade.

2.5 Sloping Grain Interpretation

- (a) A Contractor must consider the following points when measuring sloping grain:
- (i) Sloping grain is when the grain of the log does not run parallel but angles across the length of a log (Diagram 2).
 - (ii) To check sloping grain, measure the distance 'S' over a 2.7m length and compare it to the longitudinal length as shown. If the ratios below are exceeded, then the log should be downgraded appropriately:
 - B Grade 1:10
 - C Grade 1:8
 - D Grade 1:8

Diagram 2

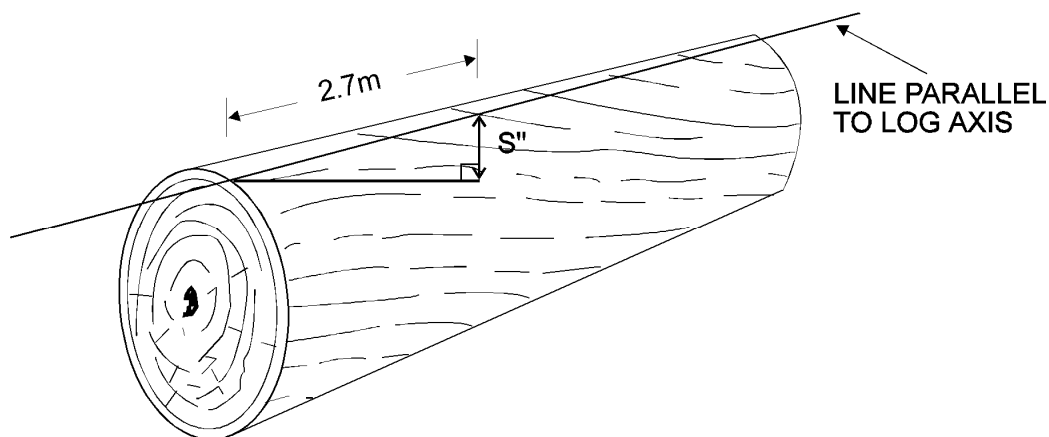

All printed copies of this procedures are uncontrolled. The latest version can be found at www.vicforests.com.au

2.6 Stem Defect

- (a) A Contractor must consider the following points when measuring stem defect:
- (i) Stem defect is a defect extending into the heartwood which significantly reduces the recovery of sawn timber of the lowest merchantable grade; and
 - (ii) Stem defect will only be treated as a defect when the width of the defect extends into the heartwood greater than one third of a quarter.

2.7 Mechanical damage

- (a) Mechanical damage should be minimised through appropriate handling of logs on the landing and removal of damaged sections at the landing when appropriate.
- (i) Excessive waste will be identified and treated as a performance management issue
- (b) A Contractor must consider the following points when treating slabbing or splitting due to machine damage:
- (i) Where identified, slabbing and splitting is not to be considered as a defect; and
 - (ii) A log with a split or slab that covers more than 15% of the log end and runs for more than 30 cm into the log may have a volume reduction applied upon review by a VicForests representative. A log will be deemed to have 15% of the end affected by the slab or split, if the damaged section exceeds one fifth or 20% of the log diameter.
- (c) A Contractor must identify and treat the following forms of machine damage as a defect:
- (i) Stumped and shattered wood
 - Stumped and shattered wood must be removed from the log on the landing prior to final grading and delivery.
 - The delivery of stumped or shattered wood is unacceptable and should be dealt with in the mill if discovered by culling the affected portion of the log and remeasuring the remaining section.
 - (ii) Pulled wood that extends for more than 30 cm.
- (d) If mechanical damage which is out of specification involving slabbing or splitting is detected then the volume must be recalculated. The method for the volume calculation is to:-
- (i) Measure a 2.7 m length or the length of the slabbed section, whichever is longer (note if the log is <5.4 m long the entire length must be used as it cannot be cut into two logs).
 - (ii) At the mid point of this section measure the diameter from the edge of the split, around the log and to the centre of the split (see Diagram 3). If the slabbed section remains attached to the log then an estimate will need to be made.
 - (iii) The volume of the log is determined using the standard log volume table using the length determined in (i) above and the diameter determined in (ii) above.
 - (iv) Any undamaged log section needs to be remeasured, refer Utilisation Procedures.

All printed copies of this procedures are uncontrolled. The latest version can be found at www.vicforests.com.au

Diagram 3:

Diameter Measurement of the Mechanical Damaged Section of the Log

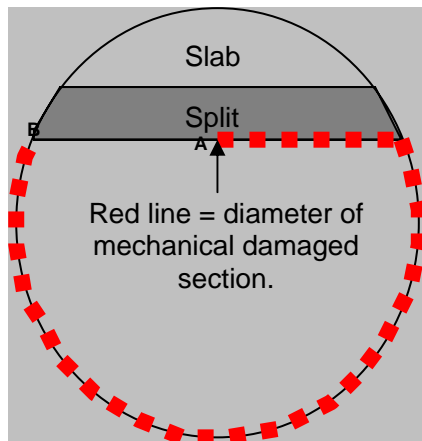

2.8 Stain

- (a) A Contractor must consider the following points when assessing stain:
 - (i) Stain can be defined as light or dark stain; and
 - (ii) Light stain has no impact on log quality; and
 - (iii) Dark stain is defined as sawn timber that will not be suitable for appearance grade timber due to discolouration.

2.9 Sweep

- (a) A Contractor must consider the following point when grading sawlogs:
 - (i) No timber may have a sweep or crook which is greater than one-fifth of the diameter of that timber at the apex of the sweep or crook, measured from a straight edge inside the sweep or crook of at least 2.4 metres.

2.10 Ambrosia

- (a) A Contractor must consider the following points when measuring Ambrosia:
 - (i) Ambrosia is a beetle that leaves small borer holes that are generally associated with dark stain; and
 - (ii) Logs should only be downgraded from a B grade, if the Ambrosia cannot be boxed or quartered out and runs the length of the log.

2.11 Black Fleck

- (a) A Contractor must consider the following points when measuring Black Fleck:
 - (i) Black Fleck appears as fine black lines radiating out from the centre of a log; and
 - (ii) Logs will only be downgraded from a B grade, if the Black Fleck cannot be boxed or quartered out and runs the length of the log.

2.12 Long Butting

- (a) If a long butt is required, a Contractor must use the procedure outlined in the Utilisation Procedures to maximise the recovery of D+ sawlog.

All printed copies of this procedures are uncontrolled. The latest version can be found at www.vicforests.com.au

Attachment 3: Off Specification Timber Procedure

In accordance with the Terms and Conditions Licences and Timber Sales Agreements and Terms and Conditions for Timber Sales, the Buyer may notify VicForests within 15 days of the date of delivery of logs to a Delivery Site of logs that the Buyer believes are Off Specification, this includes notification where log docket are not fully completed. Such notification by the Buyer is referred to as the Buyer's Notification.

Buyers Notification	The Buyer's Off Specification Notification form is shown in Attachment 3(a). The Buyer must fully complete all relevant sections of the form, and the form must be lodged with the nominated VicForests contact for that Buyer.
Log Storage	A Log to which the Buyer's Notification relates, must be stored and cared for in a manner consistent with standard industry practices for a log of that type until a VicForests' inspection is carried out and an Election to Reject, an Election to Retain, or a Notice of Removal is issued. Failure to store and care for logs in such a manner may result in the logs being unable to be regraded, and will be automatically deemed part of the Annual Timber Intake.
Inspections & Regrading	VicForests shall inspect and regrade the logs to which the Buyer's Notification relates within 15 days of its receipt of the Buyer's Notification. The logs shall be removed by the Buyer from any storage stack and laid out so that the entire log may be viewed in a safe fashion.
Election to Reject	Should a Buyer elect to reject any agreed Off Specification log, VicForests, at its own cost, must ensure that the log is removed from the Delivery Site as soon as practicable after the Buyer reloads. The Buyer may invoice VicForests for the cost of reloading in accordance with the Reloading Charge.
Notice of Removal from VicForests	Should VicForests give written notice to the Buyer electing to remove the Off Specification logs from the delivery site to which it was delivered, VicForests shall do so within 10 days of such notice. The Buyer may invoice VicForests for the cost of reloading in accordance with the Reloading Charge.

All printed copies of this procedures are uncontrolled. The latest version can be found at www.vicforests.com.au

Version: 2.1

Guardian: Manager, Sales

Last Updated: 10/09/09

Authorised: Director – Sales and Planning

Attachment 3 (a): Off Specification Notification

Attention: _____



VicForests Use Only.
 Date Notification Received: ____/____/____
 Name of Recipient: _____

OFF SPECIFICATION NOTIFICATION

From:

Company	
Site Address	
Contact	

Load Details:

Coupe Number	____ _ / ____ _ / ____ _
Forest Operation No.	
Contractor	
Grader Number	
Docket Number	
Date Load Received	____ / ____ / ____
Date of Notification	____ / ____ / ____

Disputed Log Details

If Whole Load Tick Box

	Log Number	Delivered Grade [List]	Requires Regrade [✓]	Unacceptable Presentation [✓]	Other
1					
2					
3					
4					
5					
6					
7					
8					
9					
10					

All printed copies of this procedures are uncontrolled. The latest version can be found at www.vicforests.com.au

**Attachment 4: Procedure: Variation to Pulplog Grade
Request for Pulpwood Exception Specification Form**

Date:	
From:	
To:	

Supply Zone	Region:	FMA:	Ops Area:
Coupe Number			
Coupe Name			
Contractor			

Exception requested on pulplogs 40-60cm under bark at stump of the following species:

Species	Exception Requested on	
Shining Gum (E.nitens, E.denticulata)		
Silvertop (E.sieberi)		
Cut tail (E.fastigata)		
Messmate (E. obliqua)		
Manna Gum (E.viminalis)		
River Peppermint (E.elata)		
Blue Gum (E.globulus ssp.)		
Maidens Gum (E.maidenii)		
Gully Gum (E.smithii)		
Swamp Gum (E.ovata)		
White Ash (E.fraxinoides)		
Exception granted by:	Exception start date:	Confirmed by VF
Signed by Buyer		Signed by VF

All printed copies of this procedures are uncontrolled. The latest version can be found at www.vicforests.com.au

Version: 2.1

Guardian: Manager, Sales

Last Updated: 10/09/09

Authorised: Director – Sales and Planning

Exception not granted by:	Confirmed by VF
Signed by Buyer	Signed by VF

Exception not granted because (Circle reason/s)				
Stand quality	Disturbance history	Other species present	Stand age	Aspect
Market Demand				
Contractor				
Undisclosed reasoning				
Other reason/s				

All printed copies of this procedures are uncontrolled. The latest version can be found at www.vicforests.com.au

Version: 2.1

Guardian: Manager, Sales

Last Updated: 10/09/09

Authorised: Director – Sales and Planning

Attachment 5: Firewood Species and Grade Codes.

Table 1. Firewood Species Codes

Ash Species Firewood		AS
Botanical name	Common name	
Eucalyptus delegatensis	Alpine Ash	
Eucalyptus nitens	Shining Gum	
Eucalyptus regnans	Mountain Ash	
Mixed Species Firewood		MS
Eucalyptus agglomerata	Blue Stringybark	
Eucalyptus baxteri	Brown Stringybark	
Eucalyptus bicostata	Blue Gum	
Eucalyptus botryoides	Southern Mahogany	
Eucalyptus bridgesiana	Apple Box	
Eucalyptus consideniana	Yertchuk	
Eucalyptus croajingolensis	Gippsland Peppermint	
Eucalyptus cypellocarpa	Mountain Grey Gum	
Eucalyptus dalrympleana	Mountain Gum	
Eucalyptus denticulata	Errinundra Shining Gum	
Eucalyptus dives	Broad-leaved Peppermint	
Eucalyptus elata	River Peppermint	
Eucalyptus fastigata	Cuttail	
Eucalyptus globoidea	White Stringybark	
Eucalyptus macrorhyncha	Red Stringybark	
Eucalyptus mannifera	Brittle Gum	
Eucalyptus muelleriana	Yellow Stringybark	
Eucalyptus obliqua	Messmate	
Eucalyptus pseudoglobulus	Gippsland Blue Gum	
Eucalyptus radiata	Narrow-leaved Peppermint	
Eucalyptus rubida	Candlebark Gum	
Eucalyptus sieberi	Silvertop	
Eucalyptus smithii	Gully Gum	
Eucalyptus viminalis	Manna Gum	
Durable Species Firewood		DS
Eucalyptus tricarpa/ sideroxylon	Red Ironbark	
Eucalyptus polyanthemos	Red Box	
Eucalyptus boisistoana	Gippsland Grey Box	
Eucalyptus goniocalyx	Long leaf box	
Eucalyptus microcarpa	Grey Box	

All printed copies of this procedures are uncontrolled. The latest version can be found at www.vicforests.com.au

Version: 2.1

Guardian: Manager, Sales

Last Updated: 10/09/09

Authorised: Director – Sales and Planning

Table 2. Firewood Grade Codes

Species Group	Dry Firewood	Green Firewood
Ash	AS-F	AS-G
Mixed Species	MS-F	MS-G
Durables	DS-F	DS-G

All printed copies of this procedures are uncontrolled. The latest version can be found at www.vicforests.com.au

Version: 2.1

Guardian: Manager, Sales

Last Updated: 10/09/09

Authorised: Director – Sales and Planning